

Declaration of Conformity

Hygienic drum motor

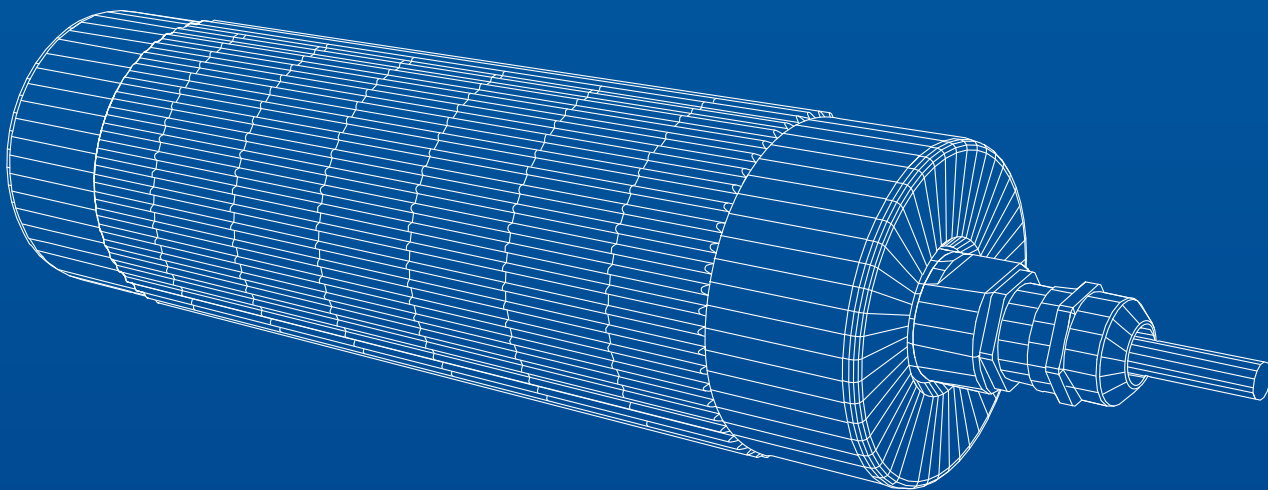

Declaration of Conformity

Document ID	DoC 08 - Hygienic drum motor
Publishing date	2024-04-25
Manufacturer	NGI A/S
Address	Virkelyst 5, DK-9400 Nørresundby, Denmark
Product type	Hygienic drum motor
Product series	XMTS and XMTD series

NGI declares that the listed product series are in compliance with the Guidelines, European Directives and standards mentioned in the Annex A as of the date this writing.

We attentively follow the revisions and amendments to these guidelines and directives and may revise our products accordingly. This declaration is subject to revision. All users are encouraged to use and apply the most recent editions of this document.

This declaration of conformity is issued under the sole responsibility of the manufacturer. It confirms compliance with indicated standards or norms but implies no warranty of properties.

On behalf of NGI

Lasse Qvistgaard Nielsen
R&D Engineer

Materials and condition of use

Please read and follow these instruction to ensure correct usage and cleaning.

Materials

Steel body	Stainless steel 1.4307 or 1.4401 with 3.1 certificate
Sealing	Black, Blue or white NBR, HNBR, EPDM or VMQ (silicone)
Axel sealing	PTFE

All sealings are in compliance with CFR title 21, 177.2600

Surfaces

Steel body:	Surface roughness <0.8µm
-------------	--------------------------

Temperature ranges

NBR:	-30°C to +120°C	-22°F to +248°F
HNBR:	-30°C to +150°C	-22°F to +302°F
VMQ:	-60°C to +200°C	-76°F to +392°F
EPDM:	-50°C to +150°C	-58°F to +302°F
PTFE	-100°C to +250°C	-148°F to +482°F

Cleaning

Detergent:	Clean with detergent suitable for supplied rubber material and steel grade
Temperature:	Do not exceed the temperature of the supplied sealing configuration

Annex A

The listed product series are conformal to the following guidelines, norms and standards.

1907/2006/EC
incl.
SVHC list 240
January 2024

Registration, Evaluation, Authorization and Restriction of Chemicals (REACH)

Under the REACH legislation, Article 33, NGL is obliged to communicate information on SVHC in articles.

We have surveyed our sub-suppliers regarding REACH and their obligation to register substances and can thus state that none of our products covered by this Declaration of Conformity contain SVHC substances above 0,10% by weight.

2011/65/EU
Incl.
amendment
2015/836

Restriction of Hazardous Substances (RoHS 1, 2 and 3)

The listed product series are free from all of the following substances covered by RoHS

- Mercury
- Cadmium
- Hexavalent chromium
- Polybrominated biphenyls (PBB)
- Polybrominated diphenyl ethers (PBDE)
- Bis(2-ethylhexyl) phthalate (DEHP)
- Butyl benzyl phthalate (BBP)
- Dibutyl phthalate (DBP)
- Diisobutyl phthalate (DIBP)

Phthalates

Phthalate free

The listed product series contains no phthalates or terephthalate plasticizers

Dodd-Frank Act

Title XV, Sec. 1502. - Conflict materials

To the best of our knowledge, the listed materials are not in any way used for manufacturing any of our products, nor does our products contain any of the listed materials.

- Gold
- Wolframite
- Cassiterite
- Coltan

DS/EN 1672-2

Food processing machinery – Basic concepts – Part 2: Hygiene and cleanability requirements

The products series contained in this Declaration follows the highest design requirements and thus then amend to material of construction 5.2.2 food area and 5.3.2 food area design.

3-A Sanitary standard 75-01

Belt-type feeders

This 3-A Standard is to establish minimum sanitary (hygienic) requirements for Belt-Type Feeders. Standard English is the official language of 3-A Sanitary Standards and 3-A Accepted Practices.